

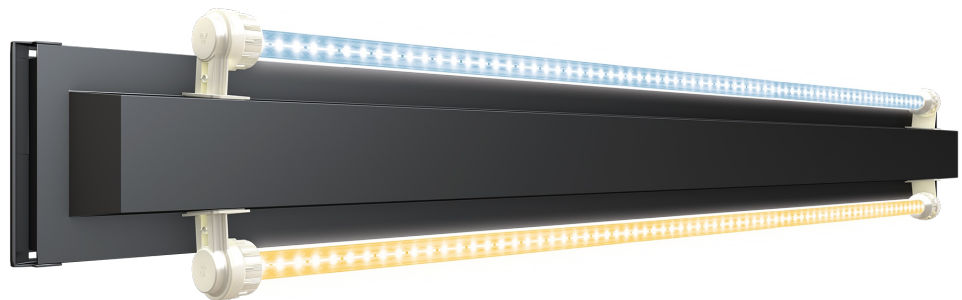

# INSTRUCTION MANUAL

## MultiLux LED



[www.juwel-aquarium.com](http://www.juwel-aquarium.com)

# Introduction

Thank you for choosing a JUWEL Aquarium product.

Our products represent over 50 years experience in the manufacturing of aquariums and their accessories applying most modern production techniques bringing together the JUWEL Aquarium system, which is both easy to use and simple to maintain.

Please read this instruction manual carefully and completely to make sure you have received all components before setting up the aquarium. Please observe the safety instructions and maintenance guidelines given in this manual.

This instruction manual has been carefully prepared to provide you with accurate and complete information. All efforts have been made to ensure that the information given is correct. However, we cannot accept responsibility for printing or other errors. Technical details are always approximate and are not warranted characteristics and may be subject to change without notice.



## SAFETY INSTRUCTIONS:

This appliance can be used by children aged from 8 years and above and persons with reduced physical, sensory or mental capabilities or lack of experience and knowledge if they have been given supervision or instruction concerning use of the appliance in a safe way and understand the hazards involved. Children shall not play with the appliance. Cleaning and user maintenance shall not be made by children without supervision.

The power plugs of the electrical devices must not become moist. Connect the power plugs to the power supply at such a height that the connection cable forms a loop which would enable the water to drip down.

At all times, only operate the electrical devices for your aquarium (lighting, heater, pump etc.) using an earth leakage circuit breaker (EL circuit breaker) with a maximum tripping current of 30 mA. If the socket that you are using in your home installation is not safeguarded with such a circuit breaker, please use a commercially available power strip with an integrated earth leakage circuit breaker.

The electrical devices may only be operated in rooms.

Pull the power plug of all devices operated in water before coming into contact with the water.

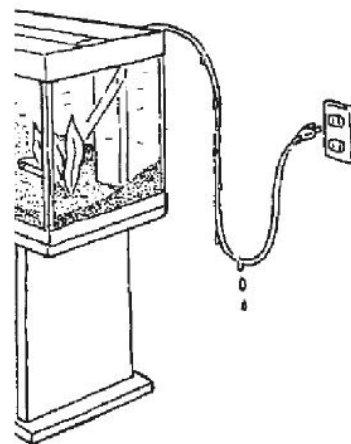

## MultiLux LED light unit

The MultiLux LED is a high-performance LED light unit for your aquarium. The replaceable LED tubes enable maximum lighting of your aquarium and ensure an energy saving of up to 50% compared to T5 fluorescent lamps.

The light unit itself is waterproof and therefore allows you to maintain your aquarium with full lighting.

## Installation of the MultiLux LED light unit

The water tightness can only be guaranteed if the tube holders have been firmly connected to their sockets and we recommend that you check this prior.

The MultiLux LED light unit may now be placed on the top frame of the aquarium and connected to the power supply. Then, attach the flaps and close the aquarium.

In that context, ensure that the top frame of the aquarium and the guide rails of the cover hatches are free of foreign objects, e.g. sand or gravel.



**TIPP Recommendation:**



**HiFlex Reflectors**

We recommend the use of suitable JUWEL reflectors that you may purchase from retailers in order to improve the luminosity. These increase the luminosity by 100% and consequently ensure a further improvement of the conditions within your aquarium.

**i Notice:**

If a defect occurs on the MultiLux LED light unit, it switches itself off automatically.

If a replacement of both LED tubes does not make the light function again, we recommend that you purchase a new light unit, which is available as a spare part.

## Maintenance and Care of the MultiLux LED light unit

The JUWEL Aquarium MultiLux LED light unit requires little care and maintenance. Only clean the frame with a soft cloth and warm water.

**Changing the LED tubes:**

In order to fault-free functionality of the light unit, it is absolutely necessary to disconnect the power plug prior to replacing the LED tubes!

Only reconnect the MultiLux LED to the power supply after this!

- Unscrew the tube holders and slide them over the LED tube.
- Remove the LED tubes from the fittings.
- Prepare the new LED tube for use by sliding the tube holders over the tube.
- Insert the new LED tube into the fitting as shown in the illustration. Check the correct position.
- Screw the tube holders on tightly.
- Switch the light unit back on.

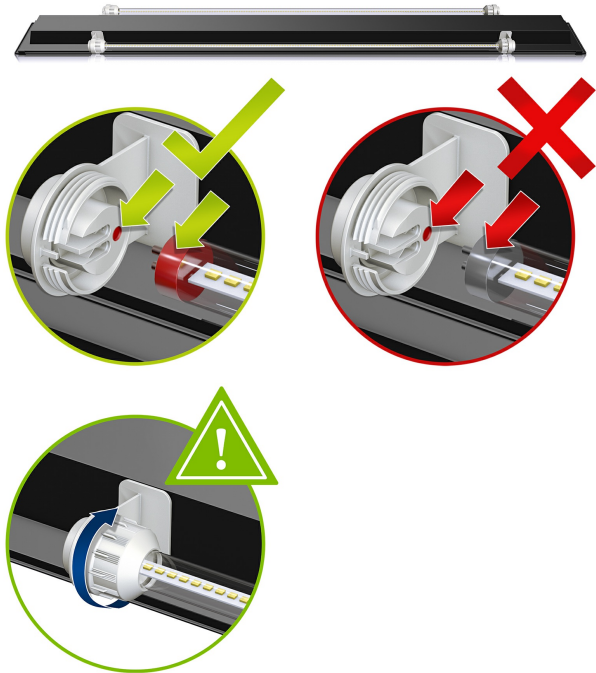

**TIPP JUWEL End Caps**



To ensure the water tightness of your Multilux light system always use genuine JUWEL Aquarium spare parts. Please note the tube holders are available from your JUWEL Aquarium retailer.



#### **SAFETY NOTICES:**

LED module – do not look into the light source! Risk Class 2

Never stare directly into the source of light for any period of time as you will otherwise risk damaging your eyes. Risk Class 2

Pull the power plug for each LED tubes replacement.

The connection line may not be repaired. Always replace the entire light unit in case of damage.

Do not operate the light unit under water.

Do not attempt to open the light unit or repair it in case of a malfunction! This would endanger the water-tightness.

The JUWEL LED tubes are coordinated with the electronic components of the MultiLux LED light unit. Therefore, only use these LED tubes as original JUWEL Aquarium spare parts.



#### **Proper disposal (electrical waste)**

The labelling on the product or on the accompanying literature declares that it must not be disposed of, at the end of its service life, together with household rubbish. Please dispose of this equipment separately from other waste, to protect the environment or public health from damage by unregulated waste disposal.

Recycle the equipment and support the sustained recycling of material resources.

Private users should contact the dealer who sold them the product or the responsible authorities, for a demonstration on how to recycle the equipment in an environmentally friendly way.

---

## Guarantee

We guarantee the performance of the JUWEL-Aquarium product or its accessories to the purchaser for a period of 24 months from the date of purchase according to the following conditions:

### § 1 Extent of the guarantee

(1) This guarantee extends to the JUWEL-Aquarium product and its components excluding items subject to wear and tear such as light tubes and filter media. It is limited to the product as such and does not cover damage to other property and/or individuals. In addition, the provisions of the product liability law apply. These provisions are not limited by the aforementioned arrangement.

(2) It is the prerogative of JUWEL-Aquarium to decide whether the guarantee is performed by means of repair or replacement. If neither repair nor replacement can ensure the performance of the JUWEL-Aquarium product the purchaser is entitled to demand a reduction in price or to return the product against repayment of the purchase price.

### § 2 Guarantee period and settlement procedure

(1) The guarantee period begins on the day of the purchase of the product from the retailer. Claims under this guarantee will not be honoured, if

- (a) the damage is caused as a result of improper use or maintenance or nonobservance of the instructions given in this manual
- (b) the product or its components have been maintained by persons or companies not authorised by the manufacturer to do so
- (c) the product or its components have been damaged by mechanical means of whatsoever kind, in particular broken glass

(2) All claims under this guarantee have to be notified to the retailer, from whom the aquarium has been purchased without delay, however, not longer than 2 weeks from the day of first occurrence of defects. Rights under the consumer protection laws will remain unaffected.

(3) Guarantee claims will only be accepted if the validity of the claim is supported by evidence of purchase of the JUWEL-Aquarium product. This declaration of guarantee is a translation only. In case of doubts the original

German language version prevails.

We reserve the right to make technical alterations.

© JUWEL AQUARIUM

\* JUWEL, Trigon, Vision, Rekord, Rio, Lido, Vio, Primo, Korall, MonoLux, DuoLux, MultiLux, KorallLux, Violux, NovoLux, PrimoLux, SeaSkim, AquaHeat, EasyFeed, High-Lite, Warm-Lite, Colour-Lite, Day-Lite, Juwel Twin-Lite, HiFlex, Juwel Ecoflow, Bioflow, Cirax, Nitrox, Phorax, Carbox, BioPad, BioCarb, BioPlus, OxyPlus, Silexo, Conexo.

AquaHeat 50W, AquaHeat 100W, AquaHeat 200W, AquaHeat 300W 220-240V, 50Hz

JUWEL AQUARIUM GMBH & CO. KG

Karl-Göx-Straße 1 27356 Rotenburg/Wümme . GERMANY

Telefon +49(0)42 61/93 79-32

Telefax +49(0)42 61/93 79-856

Service-Mail [service@juwel-aquarium.de](mailto:service@juwel-aquarium.de)

JUWEL AQUARIUM UK Branch

Gateway 11 Business Park

Penfold Drive, Wymondham Norfolk NR18 0WZ

Tel.: 01953 606 363 Fax: 01953 603 839

E-Mail: [info@juwel-aquarium.co.uk](mailto:info@juwel-aquarium.co.uk)

Service-Mail: [info@juwel-aquarium.co.uk](mailto:info@juwel-aquarium.co.uk)

[www.juwel-aquarium.com](http://www.juwel-aquarium.com)

